

REVIEW OF TRANSFORMERLESS UPFC DEVICE FOR POWER QUALITY ENHANCEMENT IN POWER SYSTEM

Deepak Somani

Department of Electrical Engineering
SS College of Engineering, Udaipur (Raj.)

DECLARATION: I AS AN AUTHOR OF THIS PAPER / ARTICLE, HEREBY DECLARE THAT THE PAPER SUBMITTED BY ME FOR PUBLICATION IN THE JOURNAL IS COMPLETELY MY OWN PAPER. IF ANY ISSUE REGARDING COPYRIGHT/PATENT/OTHER REAL AUTHOR ARIES, THE PUBLISHER WILL NOT BE LEGALLY RESPONSIBLE. IF ANY OF SUCH MATTERS OCCUR PUBLISHER MAY REMOVE MY CONTENT FROM THE JOURNAL

Abstract

In this paper, a modulation and control method for the new transformer-less unified power flow controller (UPFC) is presented. As is well known, the conventional UPFC that consists of two back-to-back inverters requires bulky and often complicated zigzag transformers for isolation and reaching high power rating with desired voltage waveforms. To overcome this problem, a completely transformer-less UPFC based on an innovative configuration of two cascade multilevel inverters (CMIs) has been proposed. The new UPFC offers several advantages over the traditional technology, such as transformer-less, light weight, high efficiency, low cost and fast dynamic response. This paper focuses on the modulation and control for this new transformer-less UPFC, including optimized fundamental frequency modulation (FFM) for low total harmonic distortion (THD) and

high efficiency, independent active and reactive power control over the transmission line, dc-link voltage balance control, etc.

Introduction

The power quality issues are so much increased in the latest time. So for power quality improvement the use of FACTS devices are increased and they become much popular compare to normal filtering devices. Facts devices used power electronics devices to improve power quality and providing control on voltage, current, power flow, stability, etc. of given transmission line or particular power system. FACTS devices can be connected with the transmission line in different configurations like series with the power system (series compensation) and shunt with the power system (shunt compensation) and in some cases it will be connected in series and shunt compensation.

The example of these configurations of facts devices are the static VAR compensator and static synchronous compensator (STATCOM) are connected in shunt. At the other side static synchronous series compensator (SSSC) and thyristor controlled series capacitor (TCSC) are connected in series.

And the third one configuration example is thyristor controlled phase shifting transformer and unified power flow controller (UPFC) are connected in a series and shunt combination. In the series compensation the FACTS devices are connected in series with the power system and they will be works as a controllable voltage source. In shunt compensation power system has been connected in shunt with the FACTS devices and they will be works as a controllable current source. The effectiveness and capability of FACTS devices are very high due to that it will increasing the power transfer capability of the transmission line and also improves the stability of the given system. In this the rating of a shunt FACT device has been selected in such a way that the receiving end voltage becomes equal to sending end voltage at which bus the shunt FACT device has been connected. A series capacitor is placed at the centre to get the maximum power transfer capability and compensation efficiency for the selected rating of the shunt FACTS device. In earlier times for power

quality improvement there is active filter and passive filter based on current source and voltage source topology has been used. But they have some limitation due to which their use has been reduced in the modern times. In place of these conventional devices there are different FACTS devices has been established and used in the power system. The unified power flow controller (UPFC) is able to control, simultaneously or selectively, all the parameters affecting power flow in the transmission line (voltage magnitude, impedance, and phase angle) [1]. The conventional UPFC consists of two back-to-back connected voltage source inverters (VSIs) that share a common dc link. The injected series voltage from Inverter-2 can be at any angle with respect to the line current, which provides complete flexibility and controllability to control both active and reactive power flows over the transmission line. The resultant real power at the terminals of Inverter-2 is provided or absorbed by Inverter-1 through the common dc link. As a result, UPFC is the most versatile and powerful flexible ac transmission systems (FACTS) device. It can effectively reduce congestions and increase the capacity of existing transmission lines. This allows the overall system to operate at its theoretical maximum capacity.

POWER QUALITY AND ROLE OF FACTS DEVICE

The definition of power quality is different for the different uses. As per the Institute of Electrical and Electronic Engineers (IEEE) Standard IEEE1100 is “the concept of powering and grounding sensitive electronic equipment in a manner suitable for the equipment.” The effects on load and faulty condition occur in the system create the power quality (PQ) problem. The PQ problems will effect on electrical equipments like x’mer, motors, generators and home appliances.

A simple definition is that “Power quality is a set of electrical boundaries that allows a piece of equipment to function in its intended manner without significant loss of performance or life expectancy.” The above definition of power quality gives us two functions for electrical devices. The first one is performance and second one is expectancy. This chapter provides information regarding power quality. In this chapter we also discuss about how we can improve the power quality in the system.

The important things which are concerned regarding the power quality are given below:-

(1) Long duration voltage variation: -

Over voltage, under voltage, Sustained Interruption

(2) Short duration voltage variation: -

Interruption, Voltage unbalance, Sag, Swell, harmonics distortion, voltage fluctuation and power frequency variations, etc.

In the electrical system there are two types of loads:-

(1) Linear load: The load in which the voltage and current is related to each other and linearly varies. The examples of linear load are motors, heaters, incandescent lamp, etc.

(2) Non linear load: The load in which the voltage and current is not related to each other and their value also not dependent to each other.

The examples of non linear loads are Arc furnace, welding, Resistance welding, etc. The nonlinear load uses high-speed electronic power switching devices for A.C to D.C conversion in internal circuits. Due to this harmonics are produced at the point of common coupling and some other problems of heating and line interference are also occurred.

The different non linear loads which produce power quality problems like waveform distortion, harmonics, arc, PC, fax machines, printers, Drives, UPS, lighting Ballasts etc.

Power Quality Issues and Its Consequences:-

The power quality problem is a problem as imbalance in voltage, current, frequency, due to that equipment failure or malfunctioning of the equipment occurred. The latest electronics equipment consumes power and electricity different compare to other conventional appliances. The power quality problems and resulting consequences are occurred due to the increase of use of switching devices, non linear loads, sensitive loads, maximum use and increase in demand of power electronics switching devices, etc.

Cost of poor power quality:-

The poor Power Quality can create lots of problems in the operating system. Due to that equipment failure, damage, reduce the quality of power, finally due to all these problems cost of the system is increased. The different consequences due to poor power quality are given as below:-

1. Equipment failure or malfunctioning.

2. Equipment overheating (transformers, motors) leading to their lifetime reduction.
3. Damage to sensitive equipment (PC's, production line control systems).
4. Electronic communication interferences.
5. Increase of system losses.
6. Need to oversize installations to cope with additional electrical stress with consequential increase of installation and running costs and associated higher carbon footprint.
7. Penalties imposed by utilities because the site pollutes the supply network too much.

The main contributors for poor power quality are given as below: -

1. Reactive power: -The reactive power creates the unnecessary loads to supply system. Due to that Harmonics, unnecessary load and stress and decrement in efficiency of the system occurs.
2. Load imbalance: The unbalanced in loads may result in excessive voltage imbalance causes the stress on load and over load problems occurs. So the power quality problems are increased.

3. The higher voltage variation causes to flicker.

All of these problems create the power quality issues due to which system down time and equipment life is reduced. Due to that the cost of the system is increased. The solution for power quality issues is that at load side power controlling devices and FACTS devices are connected. Due to these solutions the harmonics, power quality problems, waveform distortions are reduced. To fulfil these solutions for power quality problems the custom power devices and FACTS devices are used with different topologies and control for power quality improvement. According to power quality issues the operation, controlling of the FACTS devices are varied. For reliable and simple operation different control strategy based custom power devices are used easily in the system.

Unified Power Flow Controller (UPFC)

The UPFC is the most versatile FACTS-equipment and is able to insert a voltage in series with the line. This voltage can have any phase and magnitude referred to the line voltage. The UPFC consists of a parallel and a series branch, each consisting of a three-phase transformer and a PWM converter. Both converters are operated from a common dc

link with a dc storage capacitor. The real power can freely flow in either direction between the two-ac branches. Each converter can independently generate or absorb reactive power at the ac output terminals [1]. The controller provides the gating signals to the converter valves to provide the desired series voltages and simultaneously drawing the necessary shunt currents. In order to provide the required series injected voltage, the inverter requires a dc source with regenerative capabilities. One possible solution is to use the shunt inverter to support the dc bus voltage. The pulse width modulation (PWM) technique is used to provide a high-quality output voltage, to reduce the size of the required filter, and to achieve a fast dynamic response [1]. The harmonics generated by the inverter are attenuated by a second order filter, providing a low THD voltage to the transformer [3]. The Unified Power Flow Controller (UPFC) was proposed for real turn-off time control and dynamic compensation of ac transmission systems, providing the necessary functional flexibility required to solve many of the problems facing the utility industry.

The Unified Power Flow Controller consists of two switching converters, which in the implementations considered are voltage sourced inverters using gate thyristor valves, as illustrated in Fig.4.1. These inverters, labeled "Inverter1" and "Inverter 2" in the figure, are operated from a common dc link provided by a dc storage capacitor. This arrangement functions as an ideal auto ac power converter in which the real power can freely flow in either direction between the ac terminals of the two inverters and each inverter can independently generate (or absorb) reactive power at its own ac output terminal since the series branch of the UPFC can inject a voltage with variable magnitude and phase angle it can exchange real power with the transmission line. However a UPFC as a whole cannot supply or absorb real power in steady state (except for the power drawn to compensate for the losses).

Unless it has a power source at its DC terminals. Thus the shunt branch is required to compensate (from the system for any real power drawn/supplied by the series branch and the losses. if the power balance is not maintained, the capacitor cannot remain at a constant voltage. Shunt branch can independently exchange reactive power with the system. The main advantage of the power electronics based FACTS controllers is their

speed. Therefore the capabilities of the UPFC need to be exploited not only for steady state load flow control but also to improve stability.

A control strategy, in general, should preferably have the following attributes:-

- Steady state objectives (i.e. real and reactive power flows) should be readily achievable by setting the references of the controllers.
- Dynamic and transient stability improvement by appropriate modulation of the controller references. While the application of UPFC for load flow control and in stability improvement has been discussed in [3, 4], a detailed discussion on control strategy for UPFC in which we control real power flow through the line, while regulating magnitudes of the voltages at its two ports.

UNIFIED POWER FLOW CONTROLLER

The UPFC is a combination of a static compensator and static series compensation. It acts as a shunt compensating and a phase shifting device simultaneously.

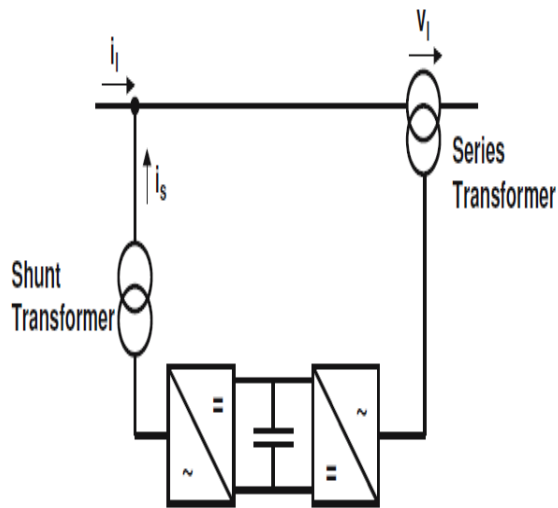

Figure 4.1 Principle configuration of an UPFC

The UPFC consists of a shunt and a series transformer, which are connected via two voltage source converters with a common DC-capacitor. The DC-circuit allows the active power exchange between shunt and series transformer to control the phase shift of the series voltage. This setup, as shown in Figure 4.2, provides the full controllability for voltage and power flow. The series converter needs to be protected with a Thyristor bridge. Due to the high efforts for the Voltage Source Converters and the protection, an UPFC is getting quite expensive, which limits the practical applications where the voltage and power flow control is required simultaneously.

OPERATING PRINCIPLE OF UPFC

The basic components of the UPFC are two voltage source inverters (VSIs) sharing a common dc storage capacitor, and connected to the power system through coupling transformers. One VSI is connected to in shunt to the transmission system via a shunt transformer, while the other one is connected in series through a series transformer.

A basic UPFC functional scheme is shown in fig.4.2

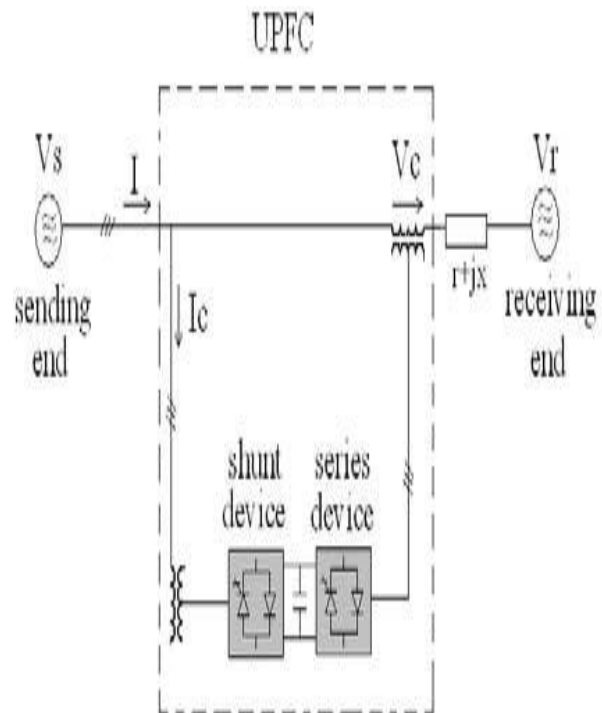

Figure 4.2 UPFC Set up Scheme

The series inverter is controlled to inject a symmetrical three phase voltage system (V_{se}), of controllable magnitude and phase angle in series with the line to control active and reactive power flows on the transmission line. So, this inverter will exchange active and reactive power with the line. The reactive power is electronically provided by the series inverter, and the active power is transmitted to the dc terminals. The shunt inverter is operated in such a way as to demand this dc terminal power (positive or negative) from the line keeping the voltage across the storage capacitor V_{dc} constant. So, the net real power absorbed from the line by the UPFC is equal only to the losses of the inverters and their transformers. The remaining capacity of the shunt inverter can be used to exchange reactive power with the line so to provide a voltage regulation at the connection point.

The two VSI's can work independently of each other by separating the dc side. So in that case, the shunt inverter is operating as a STATCOM that generates or absorbs reactive power to regulate the voltage magnitude at the connection point. Instead, the series inverter is operating as SSSC that generates or absorbs reactive power to regulate the current flow, and hence the power flow on the transmission line. The UPFC has many possible operating modes. In particular, the shunt inverter is

operating in such a way to inject a controllable current, I_{sh} into the transmission line.

The shunt inverter can be controlled in two different modes:-

VAR Control Mode: -The reference input is an inductive or capacitive VAR request. The shunt inverter control translates the var reference into a corresponding shunt current request and adjusts gating of the inverter to establish the desired current. For this mode of control a feedback signal representing the dc bus voltage, V_{dc} , is also required.

Automatic Voltage Control Mode: -The shunt inverter reactive current is automatically regulated to maintain the transmission line voltage at the point of connection to a reference value. For this mode of control, voltage feedback signals are obtained from the sending end bus feeding the shunt coupling transformer.

The series inverter controls the magnitude and angle of the voltage injected in series with the line to influence the power flow on the line. The actual value of the injected voltage can be obtained in several ways. **Direct Voltage Injection Mode:** The reference inputs are directly the magnitude and phase angle of the series voltage.

Phase Angle Shifter Emulation mode: The reference input is phase displacement between the sending end voltage and the receiving end voltage. Line Impedance Emulation mode: The reference input is an impedance value to insert in series with the line impedance. Automatic Power Flow Control Mode: The reference inputs are values of P and Q to maintain on the transmission line despite system changes. The enabling technology of modularity, scalability makes it easy installation anywhere in the existing grid. Furthermore, the transformer-less UPFC helps maximize/optimize energy transmission over the existing grids to minimize the need for new transmission lines. Resulting increase in the transfer capability of the grid, combined with the controllability and speed of operation of the devices, will enable increased penetration of renewable and demand response programs. Finally, it will reduce transmission congestion and increasing dynamic rating of transmission assets.

With the unique configuration of the series and shunt CMIs, the transformer-less UPFC has some new features:

1. Unlike the conventional back-to-back dc link coupling, the transformer-less UPFC requires no transformer, thus it can achieve low cost, light weight,

small size, high efficiency, high reliability, and fast dynamic response;

2. The shunt inverter is connected after the series inverter, which is distinctively different from the traditional UPFC. Each CMI has its own dc capacitor to support dc voltage;
3. There is no active power exchange between the two CMIs and all dc capacitors are floating;
4. The new UPFC uses modular CMIs and their inherent redundancy provides greater flexibility and higher reliability.

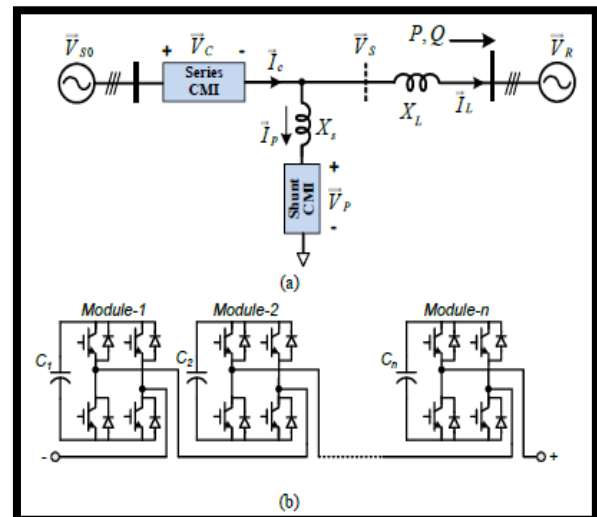

Figure 5.2 New transformer-less UPFC, (a) System Configuration of Transformer-less UPFC, (b) One phase of the cascaded multilevel inverter

MODELLING AND SIMULATION

In this model of UPFC we are using 11 KV Bus system In this we have used 3-Bus system, also used 3 level-12 pulse converter used and also some data are as follows

- 1) 3 phase source – 33kv,50 hz
- 2) Step down Transformer-33/11 kv,10 MVA,50 Hz
- 3) Base MVA-750 MVA
- 4) Base Kv-33 KV
- 5) Feeder line at load side-11kv /415V transformer(DELTA to STAR)
- 6) 3 phase RLC LOAD-415 V,10MVA,50Hz

MATLAB DESIGN OF UPFC AND CONNECTION WITH THREE PHASESYSTEM

From the above simulation results we can say that the three phase system without UPFC device generates distorted voltage, current and power. The value of these output quantities does not remains constant. So we have to interconnect the UPFC device with this three phase compensated network as shown in the fig below. As shown in the fig below the UPFC device is connected between source side and load side. The design of UPFC

includes the VSC at input side and one VSC at output side. After the interconnection of UPFC system with three phase compensated network the output value of voltage, current and power becomes constant and pure sinusoidal.

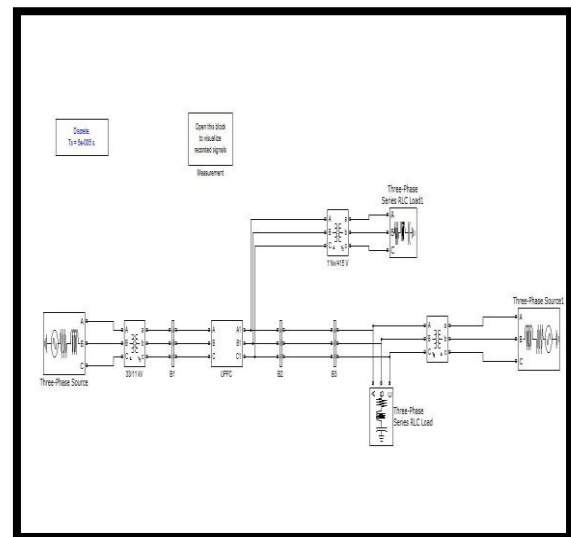

Figure 6.1 Three phase compensated network connect with UPFC system

Now the Subsystem of UPFC is shown in the fig below with their design configuration. As shown in the fig below design of UPFC includes two VSC at input and output side, which is connected through common D.C. link capacitor. The fig design configuration also includes the control circuit of gate triggering circuit for the VSC Thyristors triggering for the constant and pure sinusoidal output.

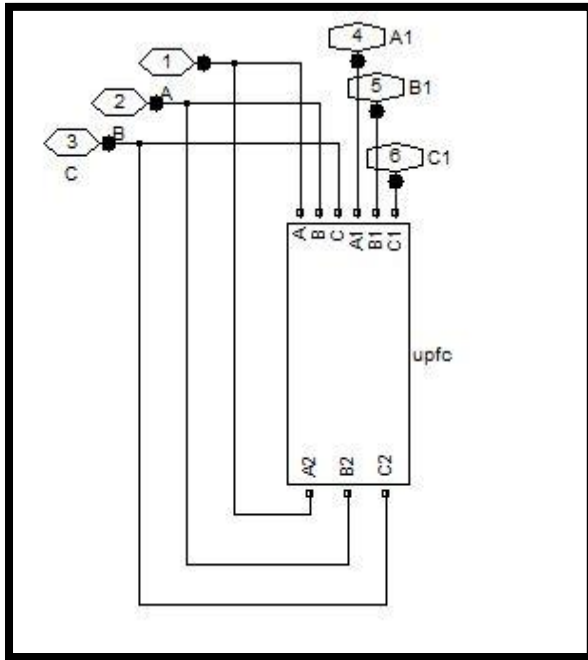

Figure 6.2 UPFC Subsystem

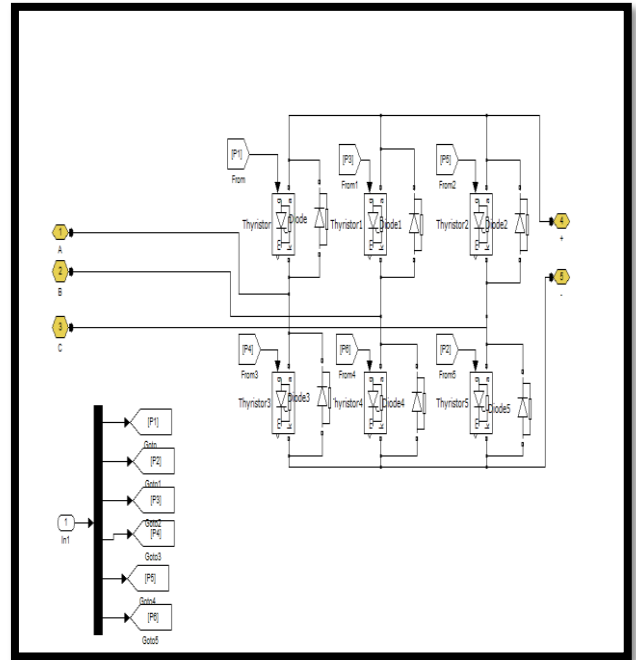

Figure 6.4 VSC configuration in UPFC design

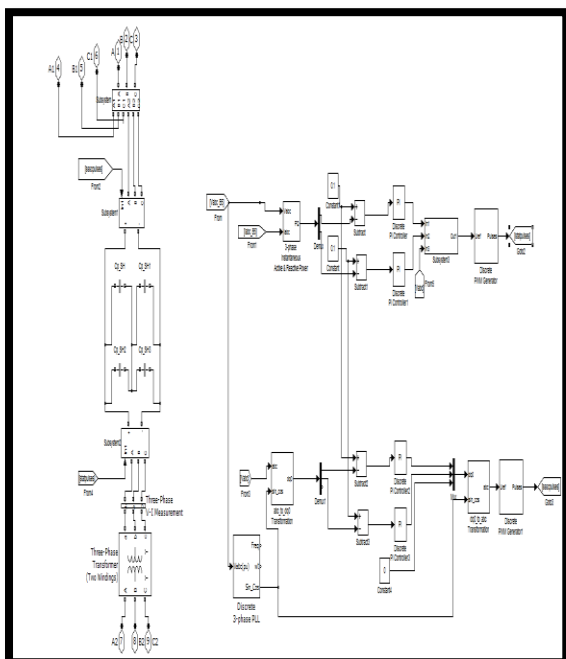

Figure 6.3 Configuration of UPFC System

The design configuration of VSC used in UPFC system is shown in the fig above. As shown in the fig above we can say that 6 Thyristors based configuration design used in the VSC at input and output side of UPFC subsystem. The gate signal for Thyristors triggering in this VSC is generated from the UPFC control strategy subsystem which is shown in the fig below:-

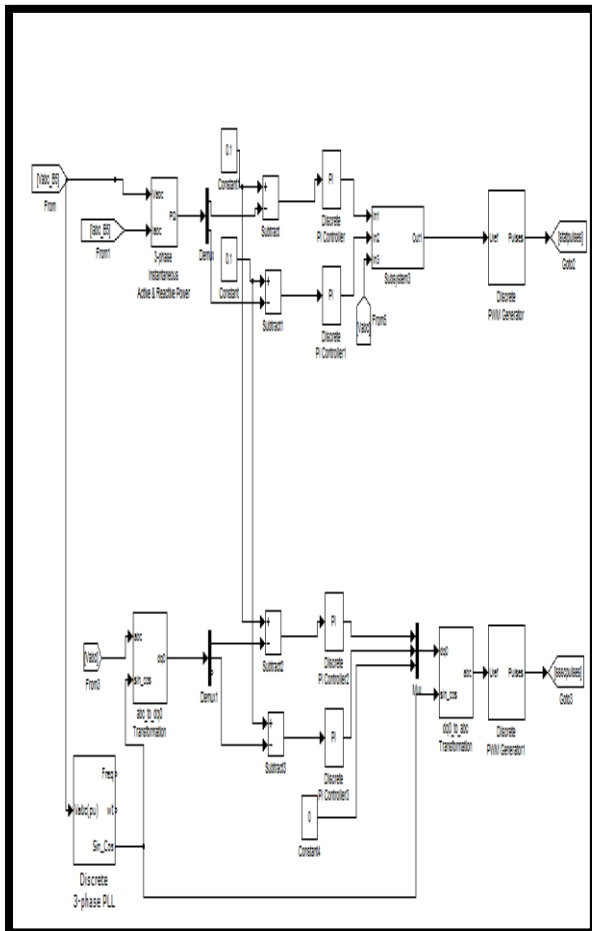

Figure 6.5 Control Strategy of UPFC System

In the control strategy of VSC at input side the voltage and current at output side is multiplied and value of power has been calculated. Then its value is compare with the constant value or add and subtract with constant value than give to PI controller for compare with the input side three phase voltages. The output of PI controller is given to PWM generator to compare with carrier frequency for pulses

generation for VSC gate triggering at input side. Same as the above the control strategy is apply for output side VSC but there is PLL (Phase lock loop) system is provided to generate the constant frequency value phase which gives the phase value constant, and dqo transformation is done is done of the 3 phase system for easiness of calculation and compare with the PI controller. The output of PI controller is inverse into 3 phase voltage V_{abc} which is given to PWM generator for comparison of carrier signal and output of PI controller.

The difference between these two signal provide pulses for gate triggering of Thyristors of VSC at output side which generates constant output value of voltage, current and power with pure sinusoidal waveform.

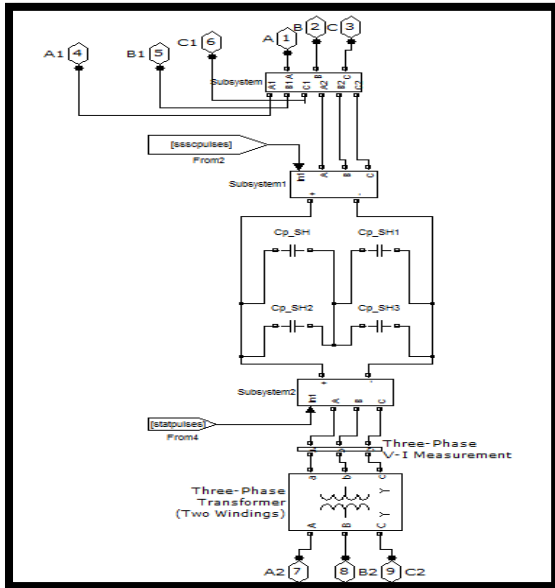

Figure 6.6 Controlling Subsystem

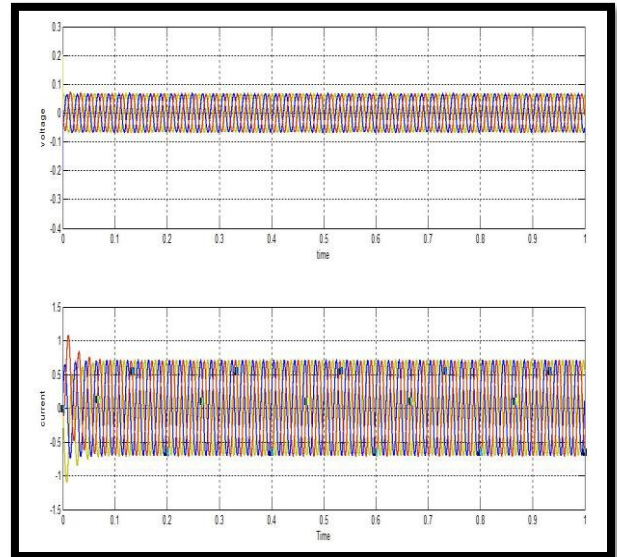

Figure 6.8 Voltage and Current waveform at Load Side

Simulation Results

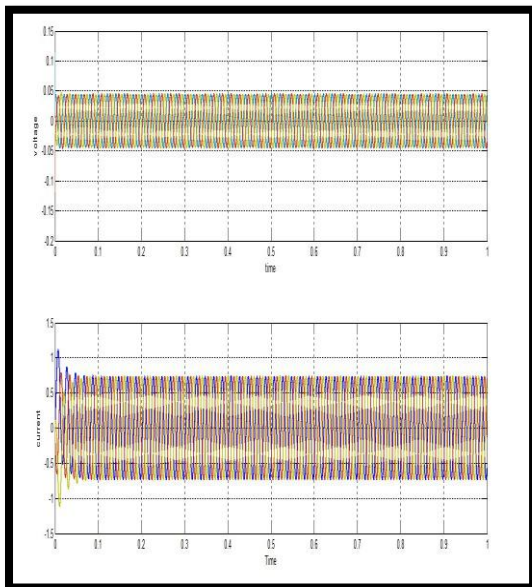

Figure 6.7 Voltage and Current waveform at Source Side (B-1)

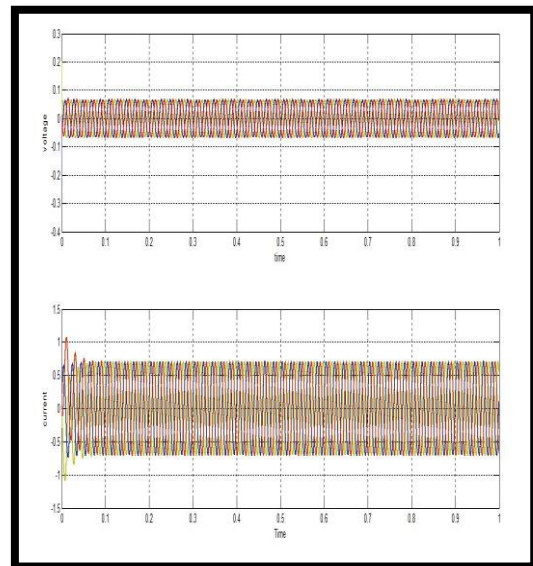

Figure 6.9 Voltage and Current waveform at load Side (B-3)

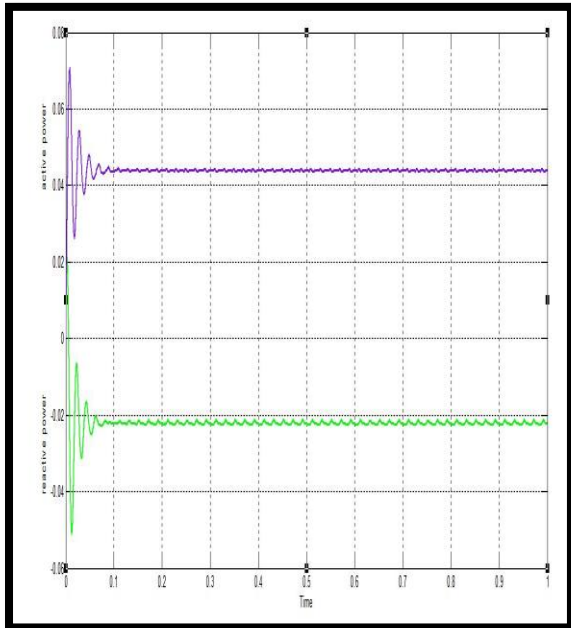

Figure 6.10 Active and Reactive Power at Source Side

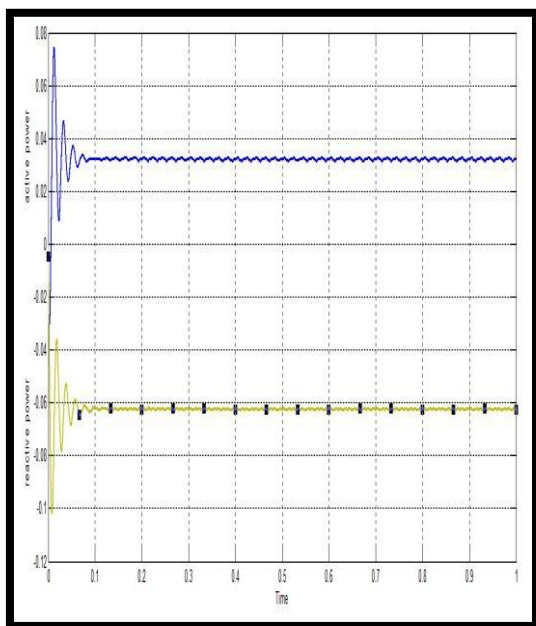
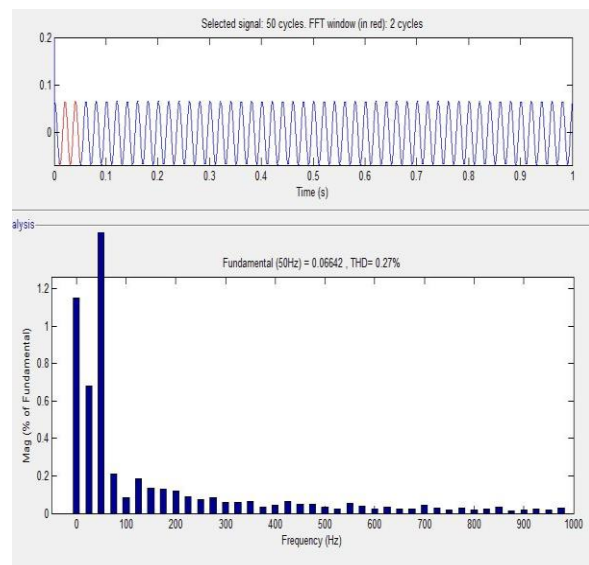
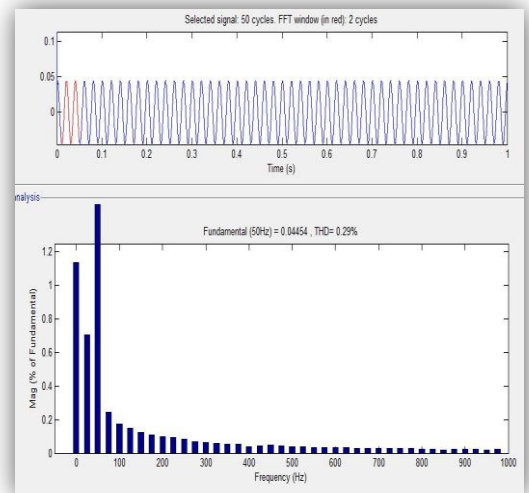
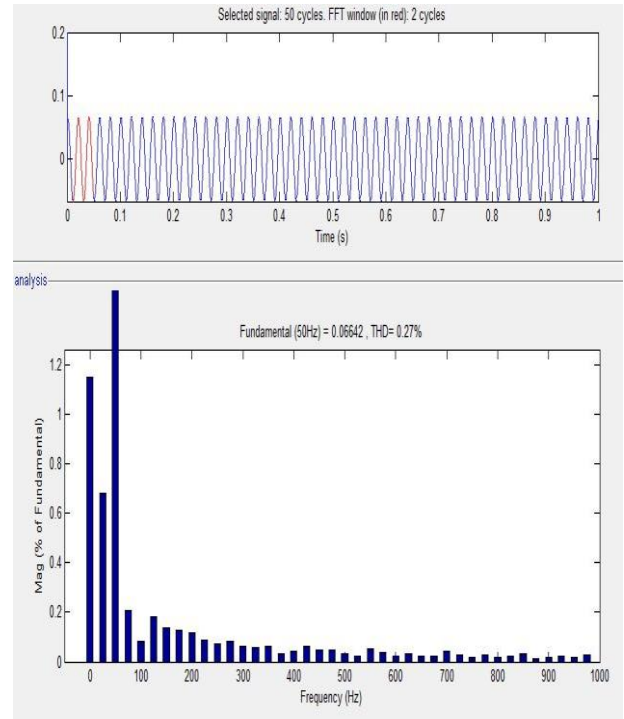
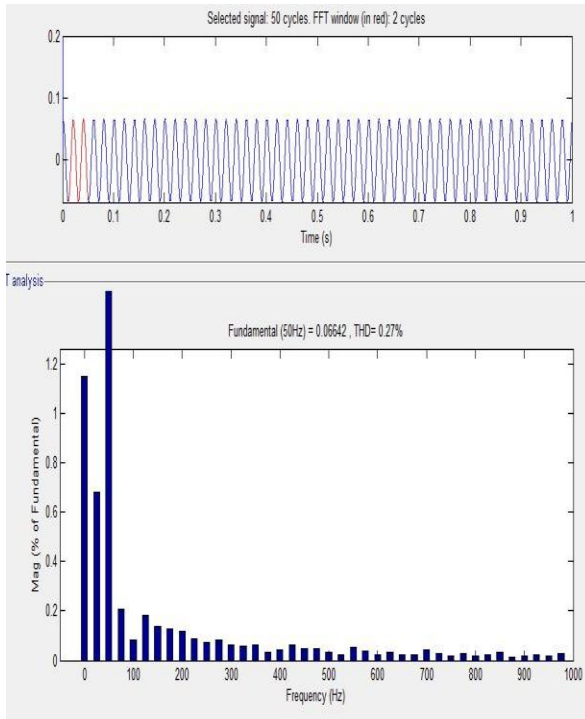

Figure 6.11 Active and Reactive Power at Load Side

THD ANALYSIS

VOLTAGE THD ANALYSIS:-





Current THD Analysis:-

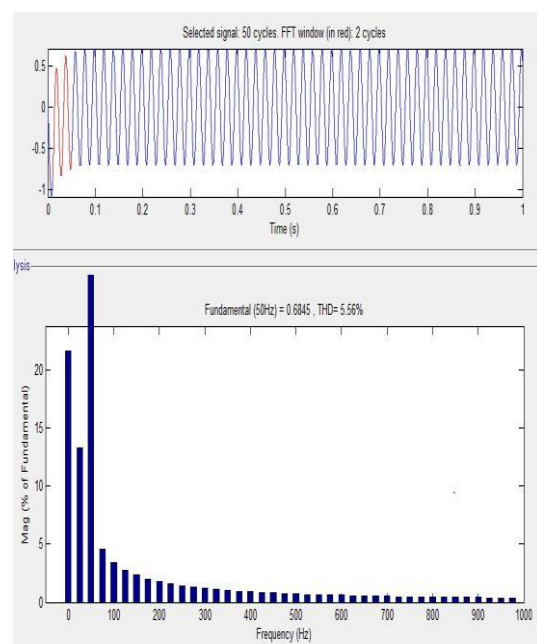
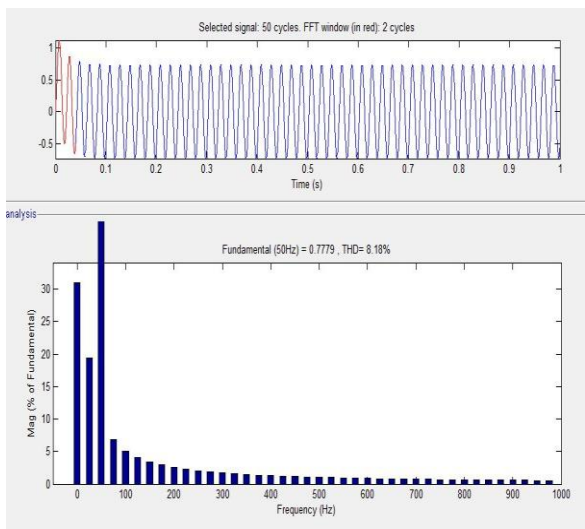

CONCLUSION

- From the simulation results we can say that after the application of UPFC in three phase system the distortion in voltage, current and power has been reduced.
- The power quality is improved using the control strategy of UPFC in three phase compensated system.

REFERENCES

- [1] N. G. Hingorani and L. Gyugyi, UnderStanding FACTS: concept and technology of flexible AC transmission systems. *New York: IEEE Press*, 2000
- [2] L. Gyugyi, C. D. Schauder, S. L. Williams, T. R. Rietman, D. R. Torgerson, and A. Edris, "The unified power flow controller: A new approach to power transmission control, " *IEEE Trans. Power Del.*, vol. 10, no. 2, pp. 1085–1097, Apr. 1995
- [3] A. Rajabi-Ghannavieh, M. Fotuhi-Firuzabad, M. Shahidehpour, and R. Feuillet, "UPFC for enhancing power system reliability," *IEEE Trans. Power Del.*, vol. 25, no. 4, pp. 2881–2890, 2010.
- [4] H. Fujita, Y. Watanabe and H. Akagi, "Control and analysis of a unified power flow controller," *IEEE Trans. Power Electron.*, vol. 14, pp. 1021–1027, 1999
- [5] H. Fujita, Y. Watanabe, and H. Akagi, "Transient analysis of a unified power flow controller and its application to design of dc-link capacitor, " *IEEE Trans. Power Electron.*, vol. 16, no. 5, pp. 735–740, Sept. 2001.
- [6] S. Kanna, S. Jayaram, and M. M. A. Salama, "Real and reactive power coordination for a unified power flow controller, " *IEEE Trans. Power Syst.*, vol. 19, no. 3, pp. 1454–1461, Aug. 2004.
- [7] C. D. Schauder, L. Gyugyi, M. R. Lund, D. M. Hamai, T. R. Rietman, D. R. Torgerson, and A. Edris, "Operation of the unified power flow controller (UPFC) under practical constraints," *IEEE Trans. Power Del.*, vol. 13, no. 2, pp. 630–639, 1998
- [8] Kim S. Y., Yoon J. S., Chang B. H., Baek D. H., "The operation experience of KEPCO UPFC," in the *Proceedings of the Eighth International Conference on Electrical Machines and Systems*, 2005, pp. 2502–2505.

[9] B. Gultekin and M. Ermis, "Cascaded multilevel converter-based transmission STATCOM: system design methodology and development of a 12 kV 12 MVA power stage," *IEEE Trans. Power Electron.*, vol. 28, no. 11, pp. 4930–4950, 2013

[10] Jin Wang, and Fang Z. Peng, "Unified power flow controller using the cascade multilevel inverter," *IEEE Trans. Power Electron.*, vol. 19, no. 4, July 2004, pp.1077–1084

[11] F. Z. Peng, S. Zhang, S. T. Yang, G. Deepak and K. Ujjwal, "Transformer-less unified power flow controller using the cascade multilevel inverter," in *2014 International Power Electronics Conference (IPEC-Hiroshima 2014 - ECCE-ASIA)*, 2014, pp. 1342-1349.

[12] F. Z. Peng, J. W. Mckeever, and D. J. Adams, "Cascade multilevel inverters for utility application," *Conference of the IEEE Industrial Electronics Society (IECON)*, New Orleans, LA, Nov.1997, pp. 437–442.
